



# *Submersible Ejector* BER



# BER/TOS-BER SUBMERSIBLE EJECTOR

## FEATURES

The powerful single direction jet current is unrivaled in vertical stirring convection. And its required shaft power is not so much changed when the depth changes.

## APPLICATIONS

- Pre-aeration and mixing at wastewater treatment plant
- Supplying oxygen to water in aquafarm

## MAJOR STANDARD SPECIFICATIONS

Air-inlet Bore		mm	25	32	50
Treating Fluid	Type of Fluid	Wastewater and Sewage			
	Fluid Temperature	0 to 40°C			
Pump	Structure	Impeller	Channel		
		Shaft Seal	Double Mechanical Seal (with Oil Lifter)		
		Bearing	Double-shielded Ball Bearing		
	Materials	Diffuser*	Structure Steel + Nylon Coated		
		Impeller	Gray Cast Iron		
		Suction Cover	Gray Cast Iron		
		Casing	Gray Cast Iron		
Shaft Seal	Silicon Carbide				
Motor	Type, Pole	Dry Type Submersible Induction Motor 2, 4-pole (2.2kW and above)			
	Insulation	Class E, F (1.5kW and 5.5kW only)			
	Phase	Three-phase			
	Protection Device (built-in)	Circle Thermal Protector			
	Lubricant	Turbine Oil (ISO VG32)			
	Materials	Frame	Gray Cast Iron		
		Shaft	Stainless Steel 403, 420 (1.5kW and above)		
Cable		PVC Chloroprene Rubber (5.5kW only)			
Air-inlet Connection	Screwed Flange				

\*Available in stainless steel 304 upon request

## STANDARD SPECIFICATIONS

Air-inlet Bore mm	Frequency Hz	Model		Motor Output kW	Speed (s.s.) min <sup>-1</sup>	Starting Method	Air Flow Rate -Water Depth m <sup>3</sup> /h-m	Mixing Capacity m <sup>3</sup> /h	Max. Tank Dimension			Max. Water Depth m	Dry Weight*2 kgs	
		Free Standing	Guide Rail Fitting						Length m	Width m	Depth m		Free Standing	Guide Rail Fitting
25	50	8-BER4	TOS-8BER4	0.75	3000	D.O.L.	11-3	22	3	2	4	4	28	23
	60	8-BER4	TOS-8BER4	0.75	3600	D.O.L.	9-3	21	3	2	3.5	3.5	28	23
32	50	15-BER3	TOS-15BER3	1.5	3000	D.O.L.	28-3	41	4	3.5	4	4	43	34
	60	15-BER3	TOS-15BER3	1.5	3600	D.O.L.	24-3	40	4	3.5	4	4	43	34
50	50	22-BER5	TOS-22BER5	2.2	1500	D.O.L.	45-3	63	5	5	4.5	4.5	75	61
		37-BER5	TOS-37BER5	3.7	1500	D.O.L.	80-3	94	6	6	5	5	91	77
		55-BER5	TOS-55BER5	5.5	1500	D.O.L.	120-3	126	7	7	6	6	149	132
	60	22-BER5	TOS-22BER5	2.2	1800	D.O.L.	38-3	60	5	5	4.5	4.5	75	61
		37-BER5	TOS-37BER5	3.7	1800	D.O.L.	70-3	90	6	6	5	5	91	77
		55-BER5	TOS-55BER5	5.5	1800	D.O.L.	105-3	120	7	7	6	6	149	132

\*1 The air flow rates are expressed at the standard condition. : Temperature 20°C, 1 atm

\*2 All weights excluding cable  
Weights of guide rail fitting model excluding duckfoot bend

## STANDARD ACCESSORIES

### Free Standing

- Silencer & Valve Set ..... 1 set
- Lifting Chain (5m / with Shackles) ..... 1 set
- Suction Casing (with Nozzle Ring, Packing & Bolts) ..... 1 set
- Screwed Flange (with Packing & Bolts) ..... 1 set
- Diffuser (with Packing & Bolts) ..... 1 set
- Diffuser Base (with Nuts) ..... 1 set

### Guide Rail Fitting

- Silencer & Valve Set ..... 1 set
- Lifting Chain (5m / with Shackles) ..... 1 set
- Guide Support (with Bolts & Nuts) ..... 1 set
- Air-inlet Pipe Support (with U-bolt & Nuts) ..... 1 set
- Guide Hook (with Bolts) ..... 1 set
- Nozzle (with Nozzle Ring, Packing & Bolts) ..... 1 set
- Suction Casing ..... 1 set
- Guide Connector (with Bolts) ..... 1 set
- Screwed Flange (with Packing & Bolts) ..... 1 set
- Diffuser (with Packing & Bolts) ..... 1 set
- Foundation Bolts (with Nuts) ..... 1 set



## CONVECTION PATTERN

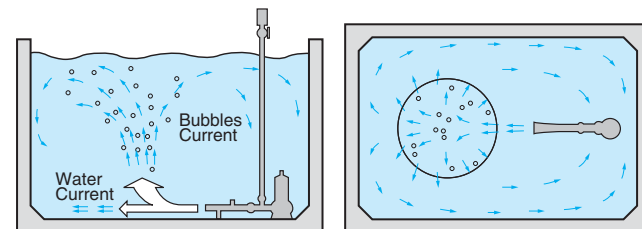

## CABTYRE CABLES

Motor Output kW	200~240V		380~575V		Material	Length m
	Cores×mm <sup>2</sup>	Dia. mm	Cores×mm <sup>2</sup>	Dia. mm		
0.75	4×1.25	11.1	4×1.25	11.1	PVC	6
1.5	4×1.25	11.1	4×1.25	11.1		
2.2	4×2	11.8	4×1.25	11.1		
3.7	4×3.5	13.9	4×2	11.8		
5.5	4×3.5	14.1	4×3.5	14.1	Chloroprene Rubber	8

## AIR FLOW RATE - WATER DEPTH CURVES

(The air flow rates are expressed at the standard condition, i.e. temperature of 20°C, 1 atm and may vary by up to approximately 5%.)

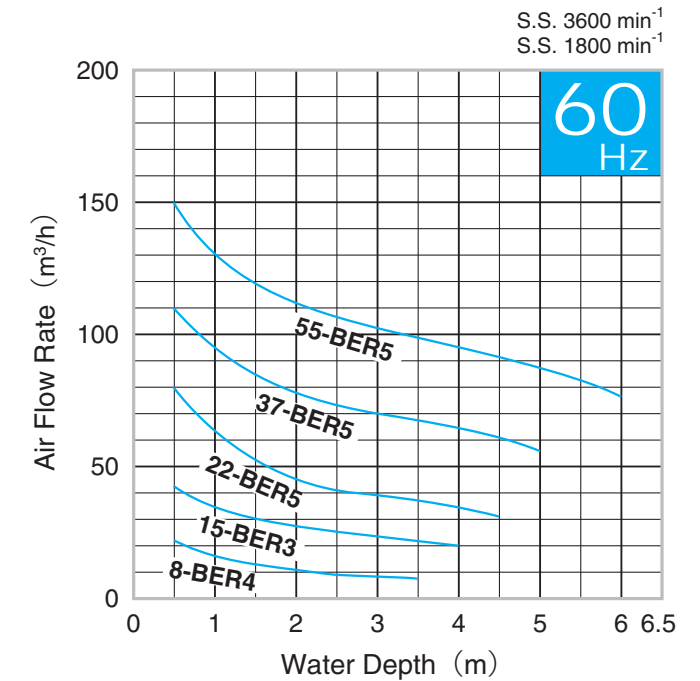
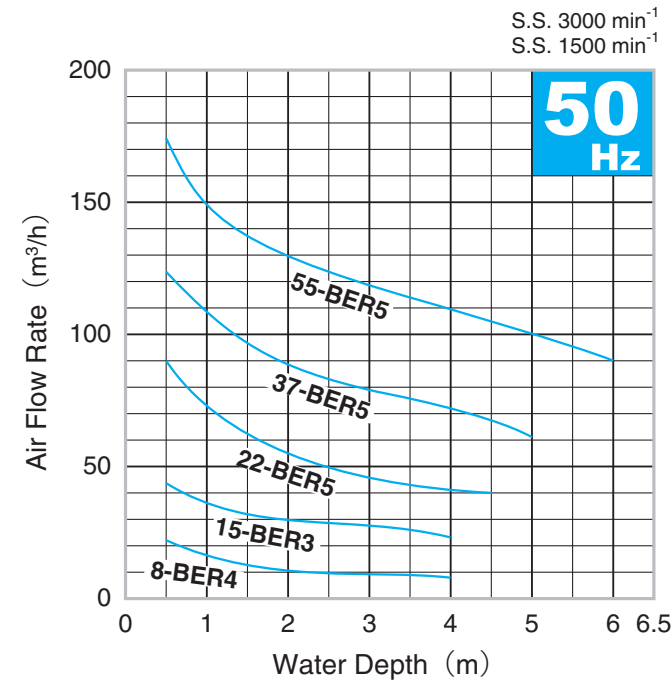

## DIMENSIONS

### Free Standing

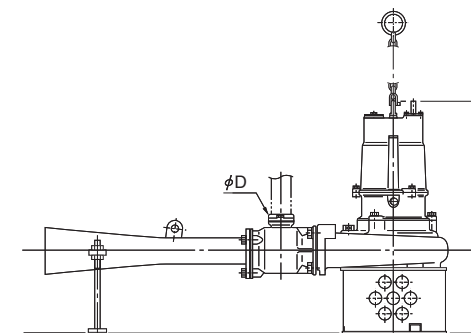
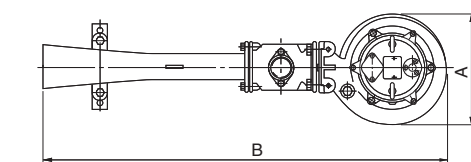

### Guide Rail Fitting

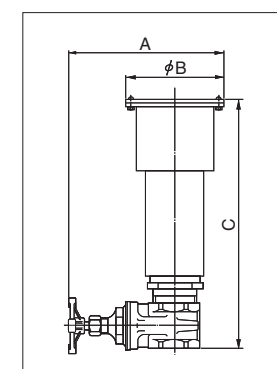
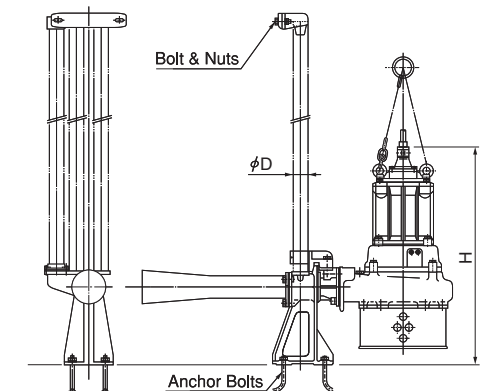
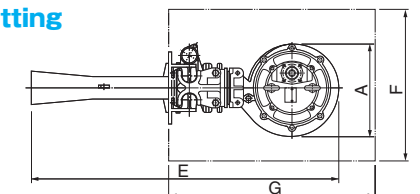

### Silencer & Valve Set

Pipe Bore	A	B	C
φ25	147	91	210
φ32	180	116	275
φ50	230	154	370

Material of silencer : PVC

(Units: mm)

Free Standing	8-BER4	15-BER3	22-BER5	37-BER5	55-BER5
Guide Rail Fitting	TOS-8BER4	TOS-15BER3	TOS-22BER5	TOS-37BER5	TOS-55BER5
A	194	222	317	325	391
B	674	895	1158	1164	1415
C	464	562	679	753	942
D*	25	32	50	50	50
E	674	910	1162	1168	1422
F	350	450	450	450	500
G	550	650	700	700	750
H	514	603	768	837	1006

\*Nominal size

# BER/TOS-BER SUBMERSIBLE EJECTOR

The Tsurumi Submersible Ejector, as shown in the figure, draws air in from the vicinity of jet nozzle by means of the water power discharged from the submersible pump. A mixture of air and water is then produced inside the diffuser. This mixture is pressurized just to the point where the pressure exceeds the water pressure around the ejection outlet, and then it forcibly jets into the surrounding water.

As a result, the ejected current is jetted in a single direction for a comparatively long range, enabling the generation of an extremely large churning effect.

Furthermore, even if the water depth fluctuates, the required shaft power hardly changes. The air quantity is freely adjusted as well. Because of this, the submersible ejector is also ideal as a aerator in equalizing tanks where the fluctuation in the water level is comparatively great.

A particularly large sales point is the fact that due to the air/water collision that occurs while the suction-induced air is in a minutely particulated, pressurized state, the oxygen dissolution efficiency is remarkably high.

## The principle of the ejector system

This system is a combination of a submersible pump and a jet pump. By the action of the ejection current of the submersible pump, a self-feeding force is generated, which draws air from the surface of the water through a air-inlet pipe. This air is mixed with the water and the mixture is ejected. The churning force caused by this ejection current is remarkably strong, with the result that exceptionally efficient oxygen dissolution is produced.

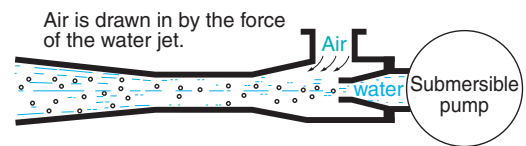

The mixture is pressurized to the point (exceeding the water pressure), where it can be ejected.

As a result, minute air bubbles and water are ejected in a pressurized state, enabling a large amount of oxygen to be dissolved in the water.

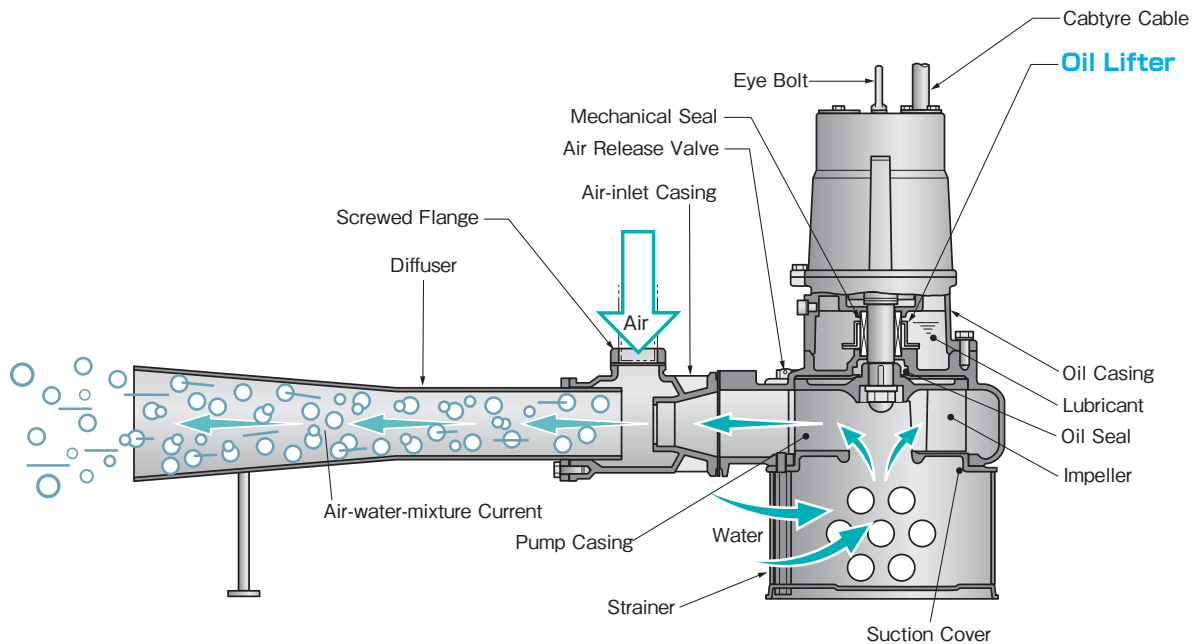

We reserve the right to change the specifications and designs for improvement without prior notice.

**TSURUMI**  
**MANUFACTURING CO., LTD.**

Your Dealer