



Submersible Sewage Pumps  
**Cutter Impeller**

C



**The C-series incorporates a cutter mechanism consisting of a tungsten carbide tipped channel impeller and a saw-tooth suction cover surface hardened. The cutter mechanism cuts fibrous materials to small pieces permitting clog-free pumping.**

### Motor Protector

Each pump up to 7.5kW as standard has a built in auto-cut, self-resetting Circle Thermal Protector (CTP). Integrated in the motor housing, the CTP directly cuts the motor circuit if excessive heat builds up or an overcurrent caused by an electrical or mechanical failure occurs.

A Miniature Thermal Protector (MTP) is embedded in each winding of the motor. These MTPs are connected in series, and their wires are led out of the motor. Should the winding temperature rise to the actuating temperature, the bimetal strip opens to cause the control panel to shut the power supply.

### Mechanical Seal

The mechanical seal with two seal faces containing silicon carbide (SiC) is equipped with the oil chamber. The advantages of the seal are two-fold, it eliminates spring failure caused by corrosion, abrasion or fouling which prevents the seal faces from closing properly, and prevents loss of cooling to the lower seal faces during run-dry conditions which causes the lower seal faces to fail.

### Oil Lifter (Patented)

The Oil Lifter was developed as a lubricating device for the mechanical seal. Utilizing the centrifugal force of the shaft seal, the Oil Lifter forcibly supplies lubricating oil to the mechanical seal and continues to supply the oil to the upper seal faces even if lubricant falls below the rated volume. This amazingly simple device is not only reliably lubricates and cools down, but also retains the stable shaft seal effect and extends the inspection term.

### Cable Entry

Every cable has an anti-wicking block at the cable entry section of the pump. This mechanism is such that a part of each conductor is stripped back and the part is sealed by molded rubber or epoxy potting which has flowed in between each strand of the conductor. This unique feature prevents wicking along the strands of the conductor itself.

### Motor

The motor is a dry-type, squirrel-cage induction motor, housed in a watertight casing, and conforms to insulation classes E or F. In each of these insulation classes, all standard pumps can be used in ambient temperatures up to 40°C.

### Shaft

The high-tensile stainless steel shaft used on all pumps is designed to have adequate strength for the transmission of the full load. It is supported by C3 type, high-quality, deep-groove ball bearings.

### Impeller & Suction Cover

A sintered tungsten carbide alloy tip is brazed onto the impeller vane, and it rotates on the serrated part of the suction cover. Incoming fibrous matters are cut up by this mechanism, and this prevents clogging in the pump discharge pipes or valves.

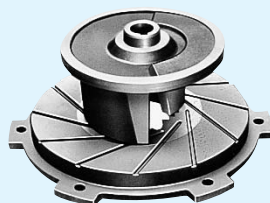
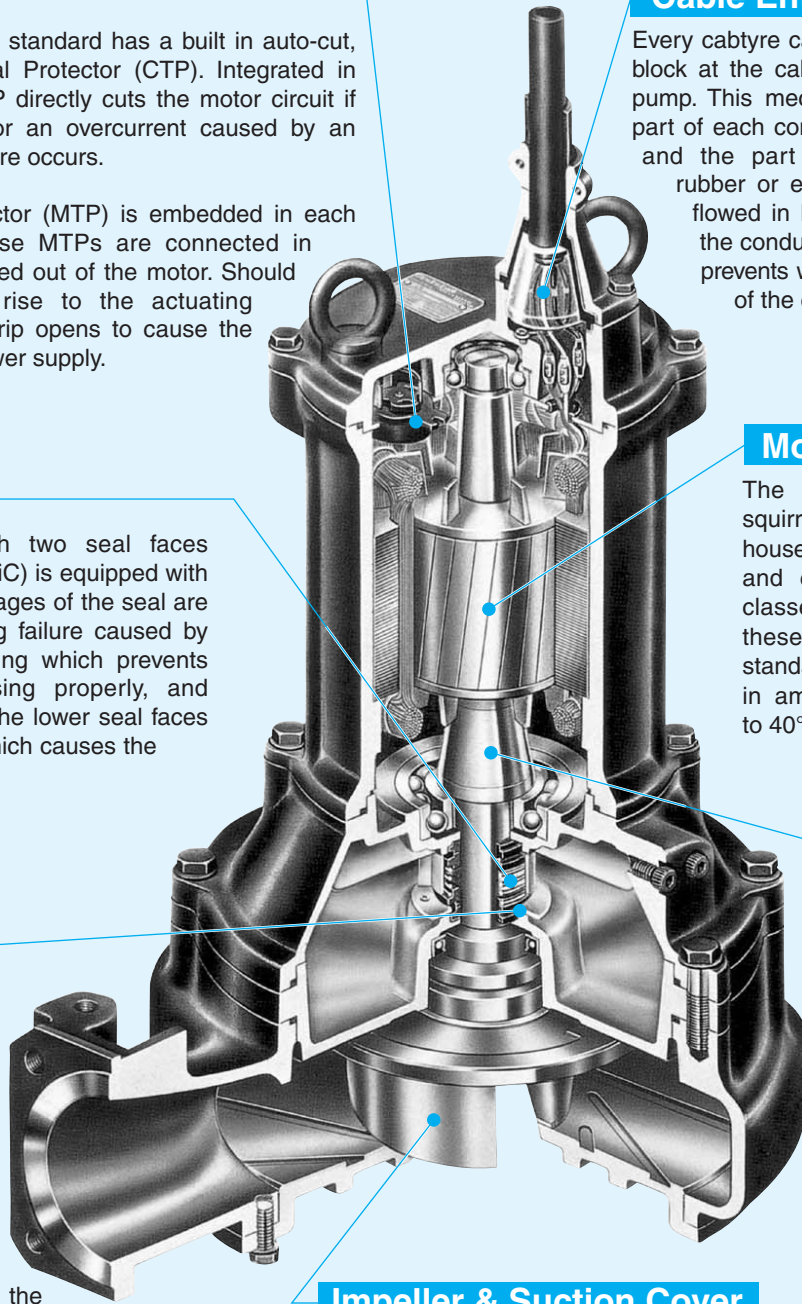

Discharge Bore  
50 • 80 • 100mm

Performance Curves

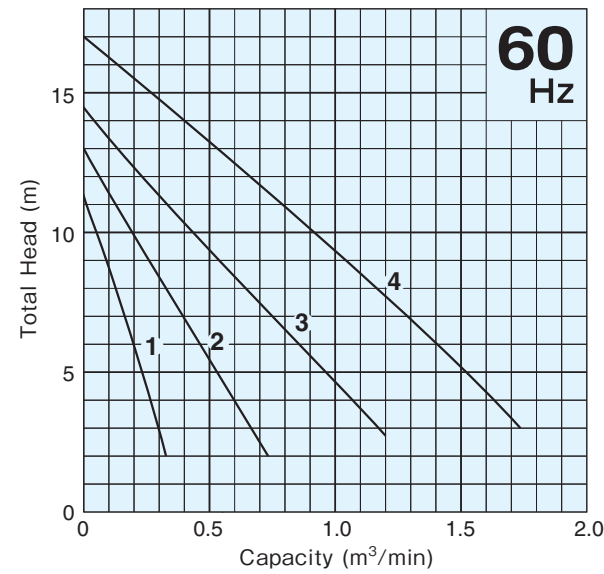
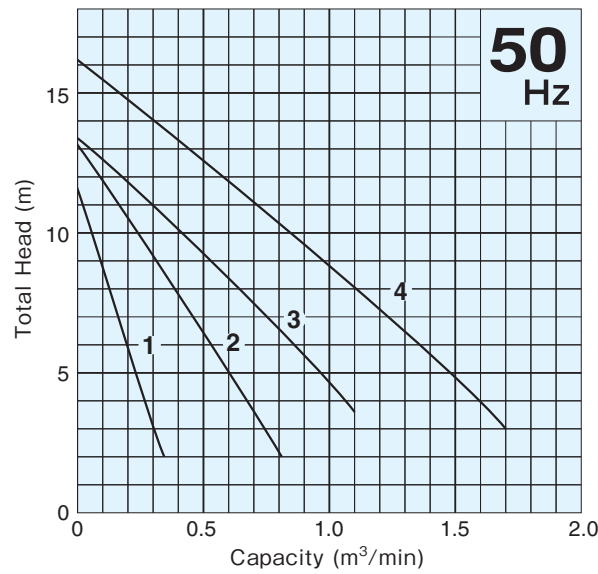

Discharge Bore  
100mm

Performance Curves

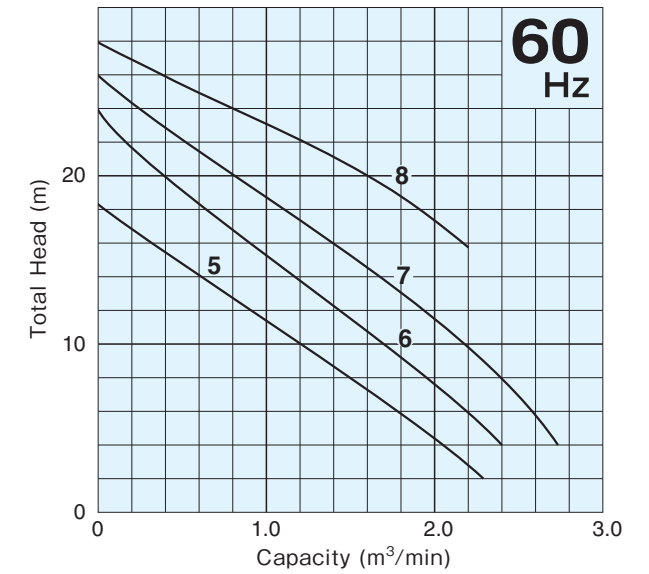
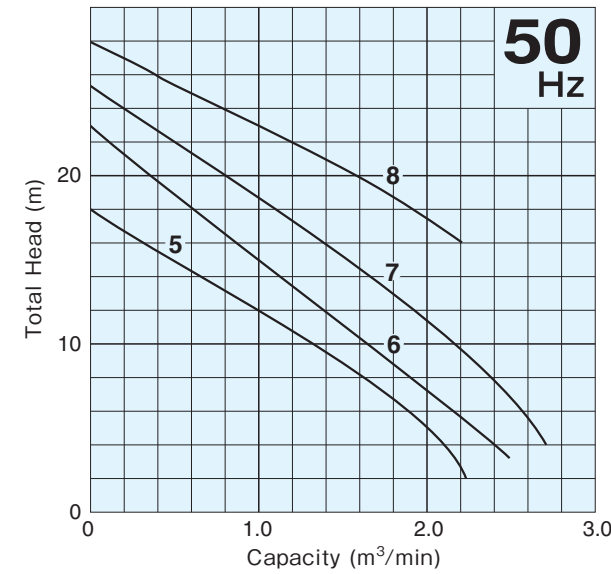

Standard Specifications 50/60Hz

Curve No.	Discharge Bore mm	Standard Model			Automatic Model			Auto-Alternation Model			Motor Output kW	Phase	Speed (S.S.) min <sup>-1</sup>	Starting Method	Solids Passage mm	Cable Length m	Cable Code	Dimensions L × H mm						Dry Weight *3 kg			
		Free Standing	Guide Rail Fitting		Free Standing	Guide Rail Fitting		Free Standing	Guide Rail Fitting									Standard Model			Auto&Auto-Alternation Model			Standard Model		Auto&Auto-Alternation Model	
			TOS	TS		TOS	TS		TOS	TS								Free Standing	TOS	TS	Free Standing	TOS	TS	Free Standing	Guide Rail Fitting	Free Standing	Guide Rail Fitting
1	50	50C2.75S	TOS50C2.75S	TS50C2.75S	50CA2.75S	TOS50CA2.75S	TS50CA2.75S	—	—	—	0.75	Single	3000/3600	Capacitor	31×27/28×27	5	a(b <sup>*1</sup> )	405×523	621×566	398×566	405×580	621×624	398×623	32	30	34	32
1	50	50C2.75	TOS50C2.75	TS50C2.75	50CA2.75	TOS50CA2.75	TS50CA2.75	50CW2.75	TOS50CW2.75	TS50CW2.75	0.75	Three	3000/3600	D.O.L.	31×27/28×27	6	A	405×415	621×458	398×458	433×496	649×539	426×539	24	23	25	24
2	80	80C21.5	TOS80C21.5	TS80C21.5	80CA21.5	TOS80CA21.5	TS80CA21.5	80CW21.5	TOS80CW21.5	TS80CW21.5	1.5	Three	3000/3600	D.O.L.	43×60/37×60	6	A	446×536	668×586	515×586	485×630	707×680	554×680	36	34	40	38
3	100	100C42.2	TOS100C42.2	TS100C42.2	—	—	—	—	—	—	2.2	Three	1500/1800	D.O.L.	67×56/62×56	6	A(C <sup>*2</sup> )	594×616	754×631	599×631	—	—	—	68	64	—	—
4	100	100C43.7	TOS100C43.7	TS100C43.7	—	—	—	—	—	—	3.7	Three	1500/1800	D.O.L.	70×81/64×81	6	C(E <sup>*2</sup> )	599×690	759×700	604×700	—	—	—	84	80	—	—
5	100	100C45.5	TOS100C45.5	TS100C45.5	—	—	—	—	—	—	5.5	Three	1500/1800	D.O.L.	82×68/68×68	8	H	686×908	905×906	710×906	—	—	—	140	133	—	—
6	100	100C47.5	TOS100C47.5	TS100C47.5	—	—	—	—	—	—	7.5	Three	1500/1800	D.O.L.	76×69/71×68	8	I	686×929	905×927	710×927	—	—	—	159	152	—	—
7	100	100C411	TOS100C411	TS100C411	—	—	—	—	—	—	11	Three	1500/1800	Star-Delta	82×75/87×75	8	L	710×1000	928×998	733×998	—	—	—	184	177	—	—
8	100	100C415	TOS100C415	—	—	—	—	—	—	—	15	Three	1500/1800	Star-Delta	87×45/77×40	8	M	707×1080	926×1078	—	—	—	—	320	313	—	—

\*1 100~120V

\*2 200~240V

\*3 All weights excluding cable

Weights of guide rail fitting model excluding duckfoot bend

Cable Code Reference

Single-Phase

Code	No. of Cables	Cores × mm <sup>2</sup>	Dia. mm	Material
a	1	3×1.25	10.1	PVC
b	1	3×2	10.9	

Three-Phase

Code	No. of Cables	Cores × mm <sup>2</sup>	Dia. mm	Material
A	1	4×1.25	11.1	PVC
C	1	4×2	11.8	
E	1	4×3.5	13.9	

Three-Phase

Code	No. of Cables	Cores × mm <sup>2</sup>	Dia. mm	Material
H	1	4×3.5	14.1	Chloroprene Rubber
I	1	4×5.5	16.8	
L	3	4×3.5	14.1	
		3×3.5 2×1.25	12.9 9.8	
M	3	4×5.5	16.8	
		3×5.5 2×1.25	15.2 9.8	

Dimensions

Free Standing

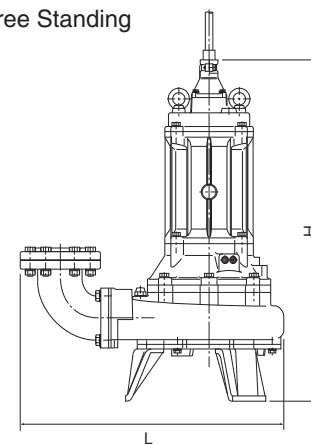

Guide Rail Fitting

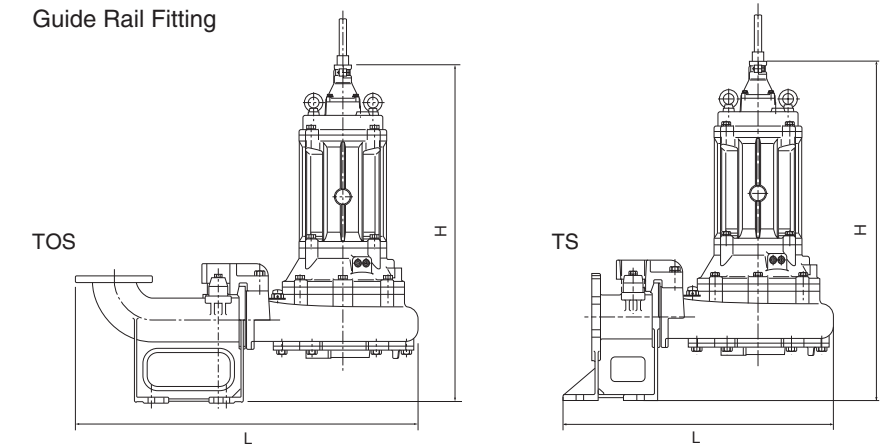

## AUTOMATIC MODEL

The Tsurumi automatic model has an integral control circuit and two float switches that operate at a low voltage. It operates automatically in response to the change in water levels. As the pump has a Circle Thermal Protector (CTP) integrated into the motor to protect the motor from overload or overheating, it is not required to provide an extra motor protection circuit in the starter panel.

This model can be identified by the suffix "A". Refer to standard specifications for availability and model numbers.



## GUIDE RAIL FITTING SYSTEM

### TOS

TOS is the Tsurumi standard guide rail fitting system. This system connects the pump to and from the piping easily just by lowering and hoisting the pump, allowing easy maintenance and inspection without the need to enter the sump.



### TS

This compact guide rail fitting system is ideal for installing in prefabricated lift stations. Its discharge flange is compatible with major flange standards including ANSI 150lb, BS PN10, and DIN PN10.



## AUTO-ALTERNATION MODEL

The auto-alternation model is used along with an automatic model. The combinational use of these two pumps enables each pump to operate alternately without control panel.

The auto-alternation model has three floats and can be identified by the suffix "W". Refer to standard specifications for availability and model numbers. It is available in the same output range of the automatic pumps.

### How the Auto-alternation Model Works

● Operation is enabled by merely connecting the power supply.

#### Primary Operation

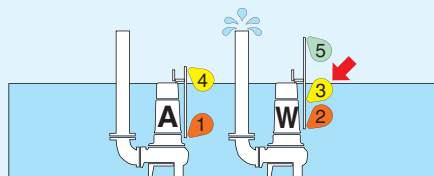

1 Float 3 operates, and pump W starts to discharge water.

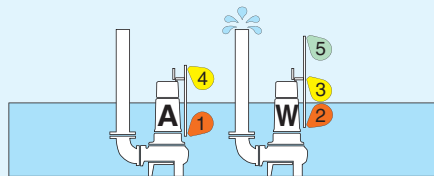

2 Water is discharged (water level falls).

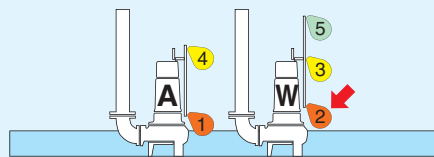

3 Stop float 2 of pump W operates to end water discharge. At this time, alternation start float 3 of pump W rests for one discharge operation.

#### Secondary Operation

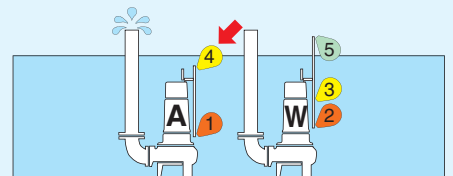

1 Start float 4 of pump A operates to start water discharge.

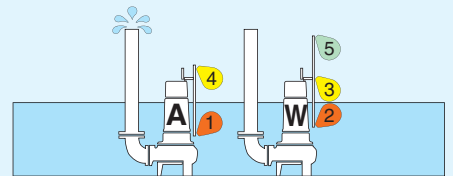

2 Water is discharged (water level falls).

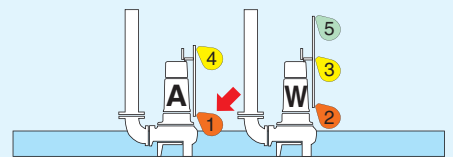

3 Stop float 1 of pump A operates to end water discharge. At the same time, start float 3 of pump W becomes ready for operation.

※Primary operation and secondary operation are repeated alternately.

※Both primary and secondary operations are performed simultaneously when water has risen to an abnormal level.

## MODEL NUMBER DESIGNATION

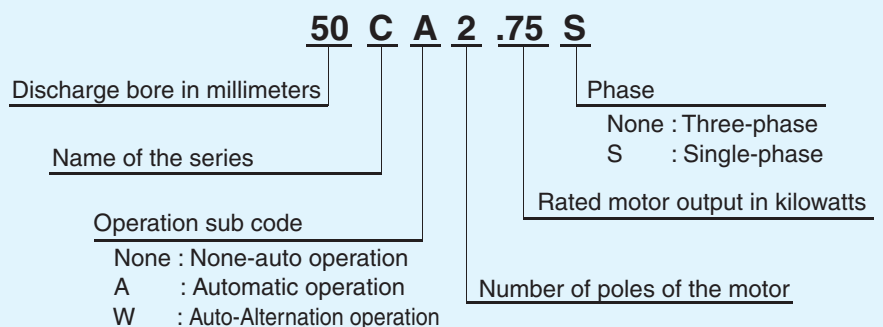

## SPECIAL ACCESSORIES

### FLOAT SWITCHES

Tsurumi offers two types of float switches (liquid level sensors). A micro-switch is incorporated in both types.

Model MC-2 is a heavy-duty type float switch with a shock absorber. Having equipped with a high grade micro switch, the MC-2 assures trouble-free operation in the liquid containing much suspended solids and floating scum. Either of the two contacts, normally-open or normally-close, can be selected as required.



Model RF-5 is an economy type float which can detect upper/lower-limit water levels with single float. The snap on-off action ensures stable operation in clean or waste water containing suspended solids or oil and fat.

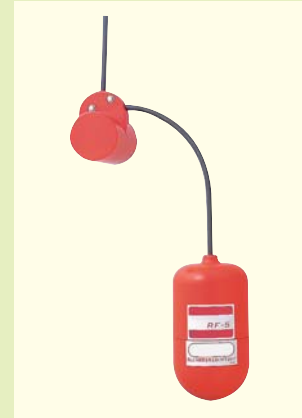

## TSURUMI OPTIONS

### SPECIAL VERSION WITH GALVANIC CORROSION PROTECTION

In sea water, the effect of galvanic corrosion is more serious than that of ordinary corrosion. When two kinds of metals are dipped into an electrolytic liquid, a battery phenomenon occurs due to the difference in the electric potential of the two metals. In this case, the metal having the higher potential corrodes first. As an option, Tsurumi can supply pumps with parts made of higher electric potential metal as the sacrificial anode.

### SPECIAL VERSION FOR HIGHER TEMPERATURE LIQUID

Standard pumps are designed for continuous running at the maximum ambient temperature of 40°C. In addition to these, Tsurumi can provide pumps for operation at higher liquid temperatures upon request. Refitting for operation at higher temperatures involves modification of not only the insulation of motor windings but also several components.

Two high-temperature operating models are available - the Rank 60 for operation in liquids up to 60°C and the Rank 90 for operation in liquids up to 90°C. Consult your dealer for more details. (These special versions are not available for some pump models.)

### DRY PIT VERSION

The advantage of dry pit model is that it will not be damaged by flooding, as it is constructed with a submersible pump. Tsurumi can provide the dry pit model as option for the whole range of C-series pumps. The water jacket covers whole part of the motor. It efficiently cools the motor for continuous operations.

### SPECIAL VERSION WITH NON-STANDARD MATERIALS

Tsurumi can also provide you with pumps with essential components such as the impeller, pump casing, and the suction cover made of non-standard materials. Select from stainless steel, chromium iron and bronze to suit your specific requirements. Consult your dealer for more details.

We reserve the right to change the specifications and designs for improvement without prior notice.

**TSURUMI  
MANUFACTURING CO., LTD.**

Your Dealer